



**MINI WEDGE RULES
2022 SEASON 5/1/2022**

DRIVERS PLEASE READ

The rules and/or regulations set forth herein are designed to provide for the orderly conduct of racing events and to establish minimum acceptable requirements for such events. These rules shall govern the condition of all events, and by participating in these events, all participants are deemed to have complied with these rules. **NO EXPRESSED OR IMPLIED WARRANTY OF SAFETY SHALL RESULT FROM PUBLICATIONS OF OR COMPLIANCE WITH THESE RULES AND/OR REGULATIONS.** They are intended as a guide for the conduct of the sport and are in no way a guarantee against injury or death to a participant, spectator or official. The race director shall be empowered to permit reasonable and appropriate deviation from any of the specifications herein or impose any further restrictions that in his opinion do not alter the minimum acceptable requirements. **NO EXPRESSED OR IMPLIED WARRANTY OF SAFETY SHALL RESULT FROM SUCH ALTERATION OF SPECIFICATIONS.** Any interpretation or deviation of these rules is left to the discretion of the officials. Their decision is final.

Rules & Regulations

Rules may be changed / amended by the track when deemed necessary.

Mini Wedge Association Mission:

To provide the safest racing program possible designed to teach young drivers 6-14 years of age the skill, sportsmanship and fair play needed to compete on and off the racetrack.

Vision:

Mini Wedge racing will be a great experience for both parent and child. Opportunities for continuous education and growth will foster personal and career growth. Our efforts will be recognized by others who view us as a benchmark for safety and fairness.

Values:

We must strive to provide a fun and safe environment for every person. We do believe all of our members desire to excel in their life. We must treat each other fairly with respect, plus offer encouragement and appreciation as we work together towards the same goals. To promote families spending good quality time together, at or away from the racetrack.

Penalties: If found with modifications to the motor or the restrictor plates or clutch the first offense Disqualified for the night and loss of points, second offense Disqualified for 2 race nights and loss of all points for the year, third will be suspended for 12 calendar months.

2022 Rules & Regulations:

The tracks encourages a fun, family atmosphere. Times may arise that are stressful and upsetting to both parents and the driver. When addressing these issues, please speak in a manner that is respectful not only to the driver, but to others that are within hearing distance.

Section 1 – Car

- Wheelbase 45” – 49”. Maximum width of the outside of the tire is 45”. There are to be no roofs, sail panels. A maximum of a 3-inch spoiler will be allowed. Spoiler side’s maximum height will be 3 inches from deck and 5 inches long.
- All karts must be constructed of steel tubing with a complete 6-point roll cage including adequate side protection. Cages must be a minimum of .065 x 1” steel tubing welded to the frame.

- The engine must be located behind the driver's seat. No part of the engine can be located beside the seat.
- Floor pans are required to be made of steel or minimum .040" aluminum. The floor pans are to be securely bolted or riveted to the frame. The length of the floor pan must go from the center of the seat to the front of the frame going past the driver's pedals.
- All karts must have a fully wedge Late Model appearing body. No open fenders will be allowed. There must be at least 4" of body behind the rear wheels. There will be no covered or enclosed motors all motors will remain completely visible at all times. See Body Drawings for more information.
- Tires must be a Hoosier (15600 "11 inches tall") FK Compound. No grooving or sipping of the tires. No treating or soaking of tires. Tires must durometer 50, any tire that durometer is 48 or less will be deemed has treated and will result in a 12-month suspension.
- Rim width cannot be any wider than 6-1/2" wide and must be at least 6" Tall.
- Axle must be a Steel Axle or Chrome Moly and a minimum of 3/16" Wall Thickness Max Length of 38". And 1 ¼ diameter.
- No free spinning rear hubs, No Ratchet style hubs
- No suspension will be allowed. This includes springs, shocks, rubbers, torsion bars and any other type of dampening devise.
- Rear deck height cannot exceed a maximum of 27.5" from the ground and a minimum of 22" high from the ground.
- Rear quarter panel cannot exceed a maximum of 24" and a minimum of 20".
- Body must be constructed of .040" aluminum. Plastic may be used for nose, fenders, and trim.
- Kart must weigh no less than 335 lbs. with driver. When tracks split the class by age, they must split it by 6-9 and 10-14 years old. The 10-14-year-old kids must weigh in no less than 375 lbs. (Tracks can choose to weigh in before or after the race.)
- We highly encourage the doors and quarter panels to be wider than the tires with at the bottom of the doors and quarters to help prevent "Wheel Hop".
- At least one vertical D door bar must be welded on each side of the driver running from the main rail to side crash bars for driver protection. See rear side view drawing for more details.
- Front and rear bumpers must be mounted at all times. Front and rear bumpers must have at least a 6" tall hoop. Rear bumpers must wrap into the inside of the wedge for bumper hooking problems.
- Front and rear down tubes are mandatory for driver's protection.
- All tubing on main roll cage must be at least .065" wall tubing.
- Driver's seat must be mounted in four locations (4-Bolts).
- Two door numbers must be present with a minimum of 12".
- Must at all times have two return springs.
- Kill switch must be mounted on the deck visible to officials.
- Any weight mounted on the kart must be painted white with the drivers name and number on the weight. Weight must be mounted by at least a ½" bolt. Any weight lost during an event will result of a two-week suspension.
- 5-Point harness system is mandatory. All harness must have a SFI Rated patch.
- All karts must have two triangle type side window nets attached to the roll bar one on each side of the driver. If you run the Full Containment seat you are not required to run a window net but are still Highly Recommended.

Section 2 - Engine

- Two engines will be allowed: 6,5 GO (212 cc) OHV Predator Engine and the Honda 6.5 HP Engine
 - Engine must remain stock. No parts to be removed except governor. No modification to be made. No internal work to be done.
 - You can disconnect or remove the governor
 - You can change the spark plug
 - You can run an aftermarket air cleaner
 - You can remove and run a remote fuel tank
 - The exhaust may not be altered in any way
 - Fuel is to be regular unleaded gas. NO ALCOHOL OR E85. Fuel samples may be taken at any time
 - All engine identification and serial numbers must remain stock. No removal or grinding allowed
 - Carburetors must remain stock to either the Predator or Honda 6.5 HP engines that they were originally sold with. May not be mix and matched
- Either engine may be claimed at the completion of the feature. See claiming procedures below
-
-

The engine claim is set at \$75 for either engine
Engines may be claimed by track officials at any time
Engines may be swapped by a track official at any time
MAX-Torque clutch is the only clutch you can run.

You can run 10, 11, 12, 13 or 14 tooth Clutches. (This is to help decrease our rear axle gear for more ground clearance.)

NO Ghost Engines and 6-9 year old class **MUST** run a GREEN (.425) restrictor plate .

Section 3 – Claiming procedures

Track Promotor/Management Claim only.

- The following are claimable: Engine, clutch, or carburetor
- The engine claim is set at \$75 for either engine.
 - Engine claim will include the carburetor.
 - Does not include the clutch, air cleaner, chain guard, throttle plate, linkages springs or gas tank
 - Engine claim does not include the restrictor plate. In the result of a claim, once the engine is removed, the restrictor plate will be removed by track official and returned upon inspection
- The carburetor claim is set at \$50.
 - Claim will include carburetor only. No springs, gaskets, or linkages
- Any part, upon inspection, found to be illegal, will be confiscated by track officials and may not be returned.
- Engines or carburetors may be claimed by a track official at any time.
- The claimed part must be removed in a reasonable period as deemed by track officials and all the parties involved.
- The claimed part must be removed in the designated tech area.
- A toolbox with the necessary tools to pull an engine is encouraged. All parts requiring inspection must be removed in the tech area.
- Any sabotage will result in a disqualification.
- Engines may be claimed by track officials at any time. Upon inspection, engines claimed by the track will be auctioned off on the following race night.
- Any engine found to be illegal will result in a suspension.
- Refusal of claim will result in suspension.
- The mission is to provide children a safe and competitive series to teach them the fundamentals, sportsmanship and completeness needed to grow into the sport as a young adult. Please keep in mind the Engine / Clutch claim is to give every child the opportunity to compete without the worry of their family not being able to afford it or their family does not "cheat" enough to be competitive.

Section 4 – Race Rules

Working receivers required for all races.

Working G3 Kart transponders are mandatory for all races at Thunderbird Raceway and Tri-City Motor Speedway. Available for rent.

-
- All drivers must be accompanied by a parent or legal guardian. Unless you are appointed his / her legal guardian, by law, you cannot sign a release form for them. Therefore, they cannot race. Any exception to this rule cannot be made by an official and must be brought before the track's management or track's insurance carrier for a decision.
- All cars will be lined up according to their pill draw. Failure to draw a pill before the lineup is turned into track officials. This will result in the driver starting at the tail of the heat.
- Arguing about scoring or judgment calls will not be tolerated. Confrontations / arguments with track officials or another parent can result in a minimal suspension of 2-weeks from all tracks.

The scoring tower is off limits to drivers and anyone who is not a track staff member.

Any parent, driver, or member of any team involved in any type of confrontation with anyone at the track

- will result in a suspension of driver and parent or legal guardian for at least two weeks from all tracks.
- Age limit is 6-14 years of age. You must provide a copy of your birth certificate before your membership can be provided.

There will be NO WARNINGS given out for bad behavior such as: No throwing a fit on the racetrack or pit area NO jumping on the track officials, officials, scorers, flagman or track owner. No going to another pit to

argue this includes driver, crew, and anyone with a Mini Wedge.

Social Media bashing of race officials, or judgement calls will not be tolerated. Race teams will be suspended for social media bashing.

Section 5 – Driver Personal Safety

- All drivers must wear an approved SFI – 1 certified or SFI13 – 2A/1 Fire Suit. SFI certification patch shall be required on fire suit.
- A Full-Face helmet will be mandatory at all tracks and all TMWA events. SA rated helmets recommended. Mandatory for 2022
- All drivers must wear a neck brace.
- All drivers must wear arm restraints. Not Mandatory but high Recommended.
- All drivers must wear a closed toe shoe. Recommended SFI shoes.

Section 6 – Body Drawing and Specs

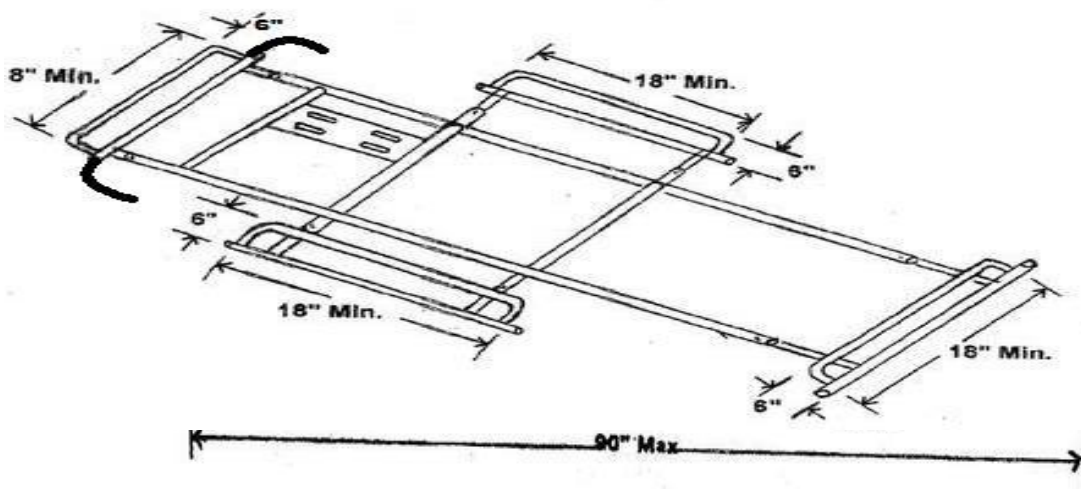
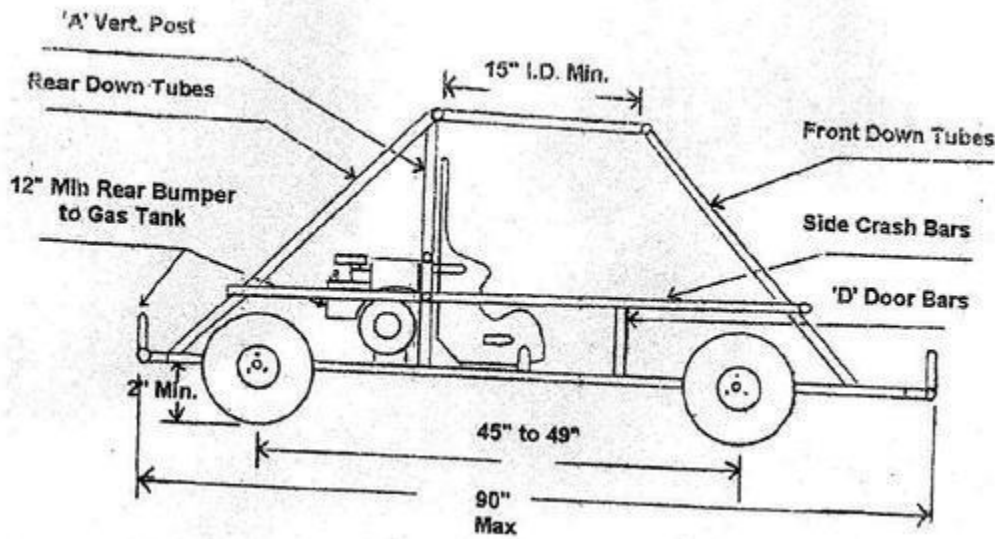

Section 7 – Point System

Points system applies to heats and features

- All ties will be broken by using the greatest number of 1st place finishes during the season. If a tie still exists, the number of 2nd, 3rd, etc. will be used in the same manner, until the tie is broken

Section 8 – Race Procedure

- Cautions will be thrown when a driver spins out and is stopped on the track.
- Caution will be thrown when a driver drives off the track and is stuck in harms way.
- The caution car (judgement call) will be put to the tail.
- Two cautions and the driver will be black flagged for that event.
- The black flag will be thrown when a driver is driving rough; this is a judgement call and cannot be argued.
- The class will be split into two classes. 6 – 9-Year-old(Restricted) and 10 – 14-Year-old
- Raceceiver is mandatory.
- Heat races will be decided on by a Pill Draw.
- Feature redraw will be set by track.
- Top 3 will receive a trophy at the end of the night in each class.
- Top 3 must report to tech area.